

No. 42ST

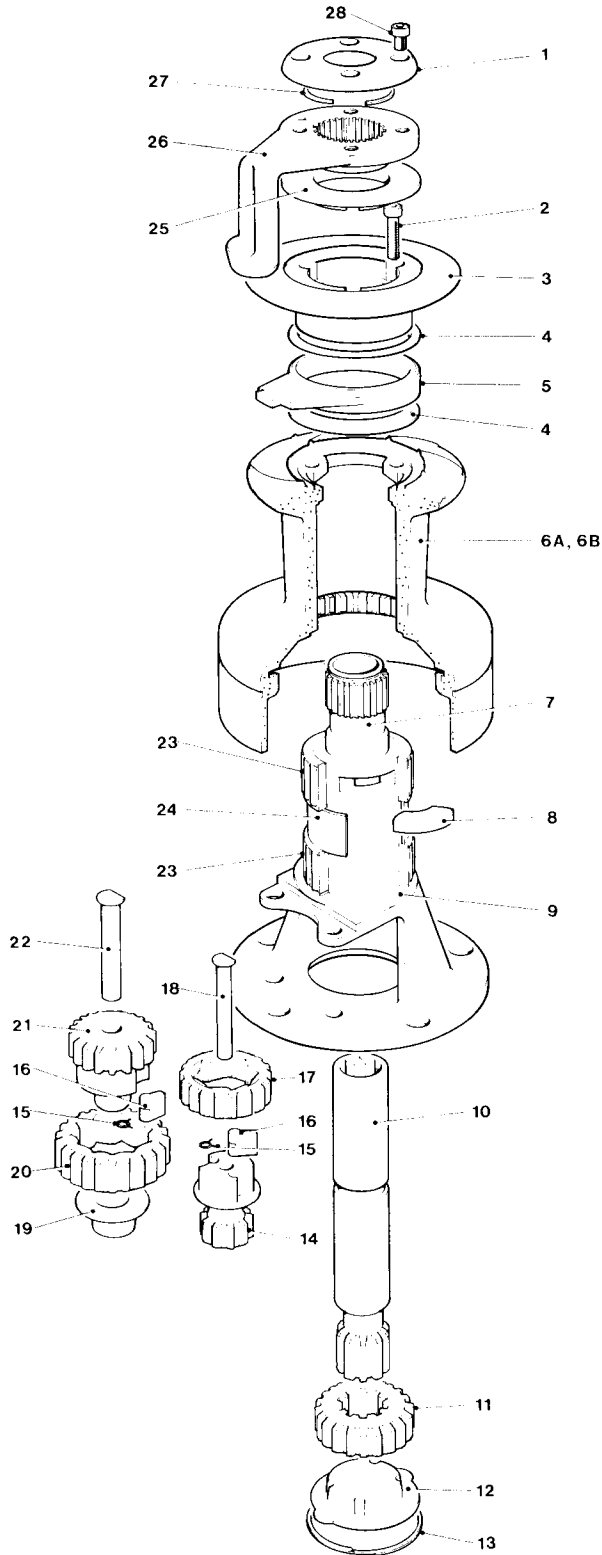

No. 42 Self Tailing Winch

Item No.	Part No.	Description	No. Off
1	15042607	Top Cap	1
2	B 0721	Skt. Hd. Cap Screw – ¼" UNC x 1" Long	3
3	15042604	Upper Crown Plate	1
4	15042641	Stripper Ring Insert	2
5	15042606	Stripper Ring	1
6A	15042402	Drum – Bronze	1
6B	15042502	Drum – Alloy	1
7	15042601	Centre Stem	1
8	15010005	Key	1
9	15042010	Drum Washer	1
10	15042603	Spindle	1
11	15042009	Gear	1
12	15016007	Retaining Plate	1
13	B 2085	Circlip	1
14	15042008	Pawl Gear	1
15	1260/7	Pawl Spring	4
16	1260/8	Pawl	4
17	15030005	Ratchet Gear	1
18	15042005	Gear Spindle	1
19	15042011	Retaining Bush	1
20	15042006	Ratchet Gear	1
21	15042007	Pawl Gear	1
22	15042004	Gear Spindle	1
23	15010007	Roller Bearing	2
24	15042012	Spacer	1
25	15042609	Flanged Bush	1
26	15042605	Stripper Arm	1
27	15042608	Collet	2
28	B 0733	Skt. Hd. Cap Screw – ¼" UNC x ¾" Long	4